

3 Einstellungen
Calibrage
Adjustments

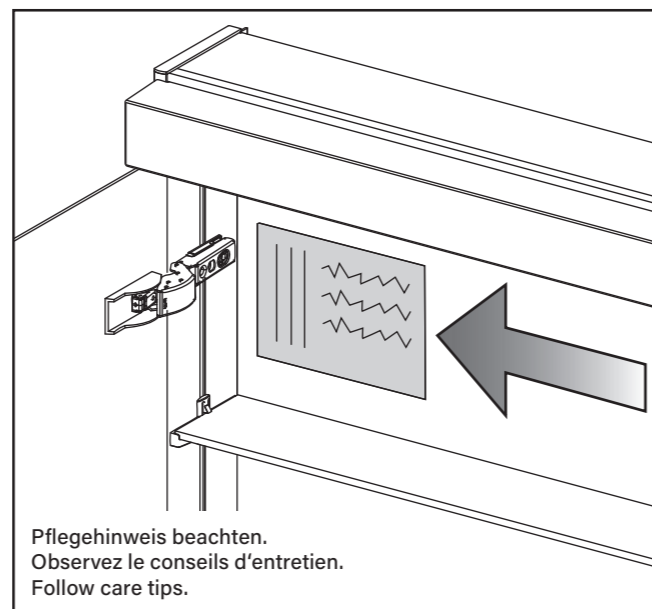

Montage-Anleitung
Instructions de montage
Assembling instructions

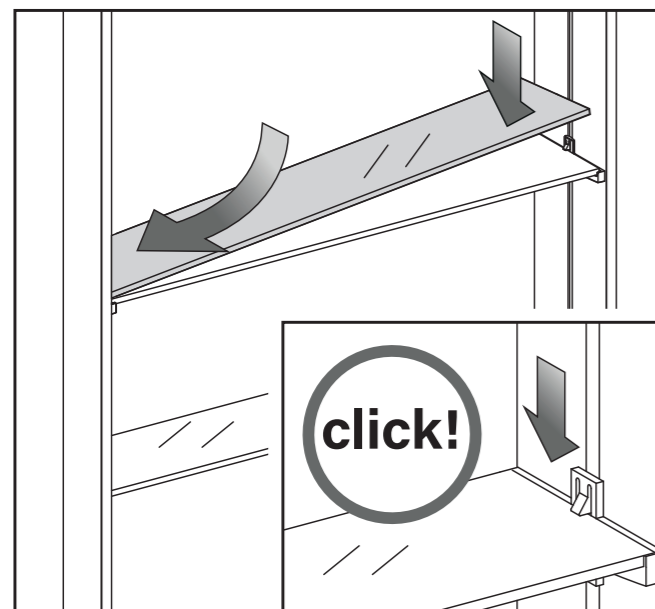
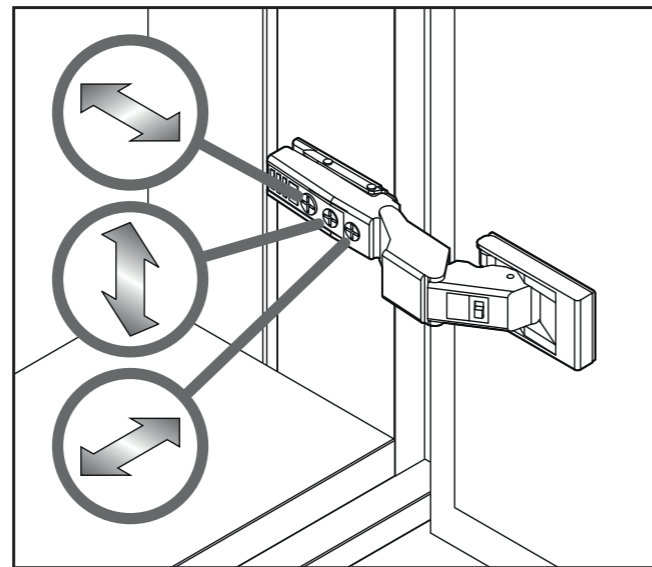
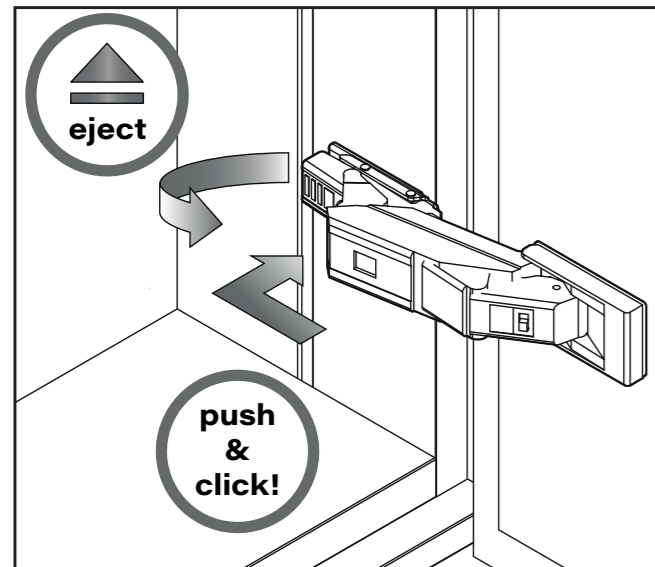
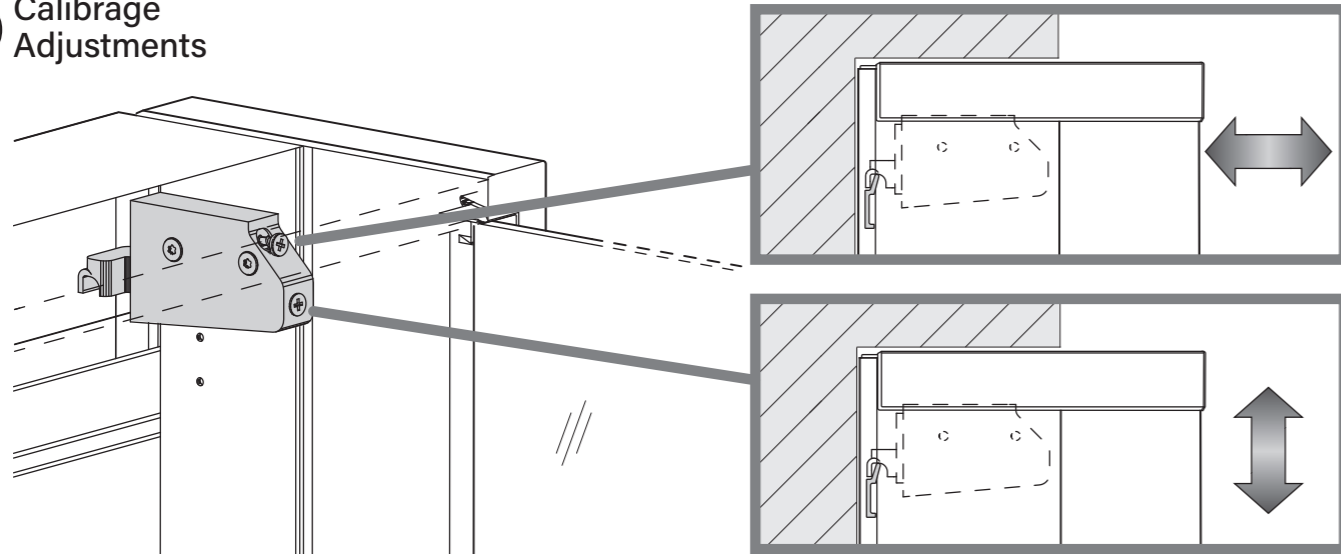
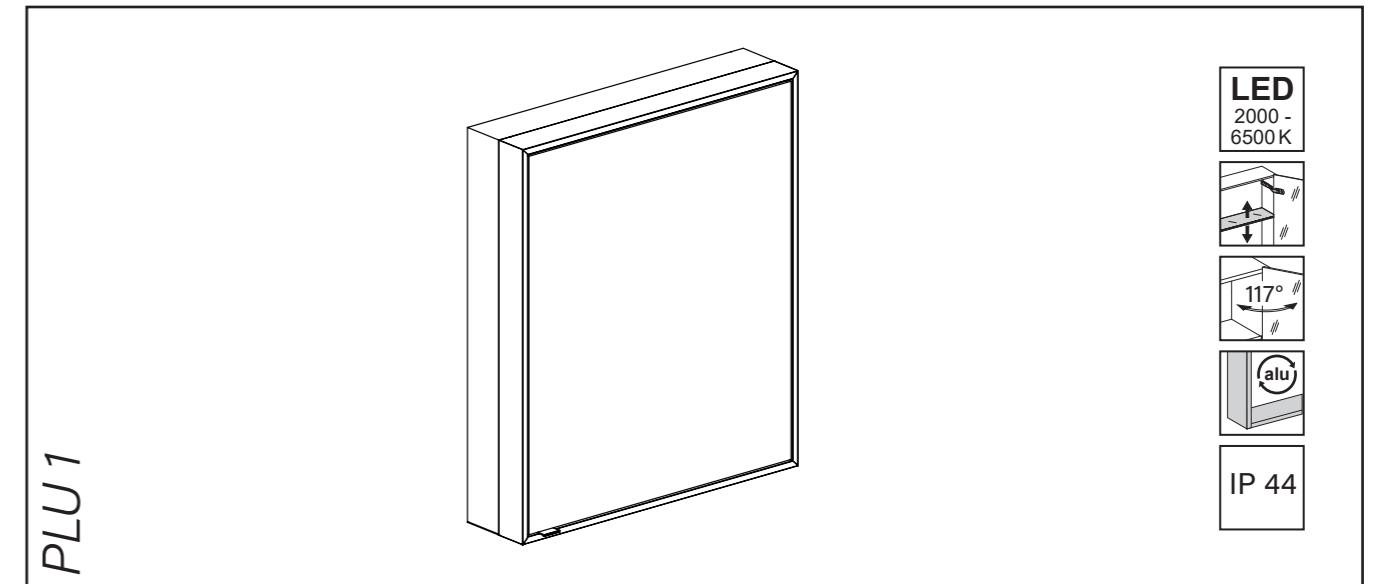

Arbeiten an den elektrischen Anlagen dürfen nur von autorisierten Fachleuten nach den örtlichen Vorschriften ausgeführt werden. Für nicht fachgerechte Installation wird jegliche Haftung abgelehnt. Die in diesem Produkt eingebauten Lichtquellen sollen nur durch den Hersteller oder eine ähnliche qualifizierte Person ersetzt werden.
Räume mit Badewanne oder Dusche müssen mit einer FI-Schutzeinrichtung (RCD) I Δ n = 30mA gesichert sein.
Bereich 2 mindestens Schutzart IP X4. Bereich 2 keine Steckdosen.



Les travaux à l'installation électrique ne doivent être effectués que par des spécialistes autorisés selon les prescriptions locales. Si l'installation n'est pas faite par un expert nous déclinons toute responsabilité. Les sources lumineuses intégrées dans ce produit ne doivent être remplacées que par le fabricant ou par une personne de qualification similaire.
Locaux avec baignoire ou douche doivent être protégés par un dispositif de protection FI (RCD) I Δ n = 30mA.
Volume 2 min. degré de protection IP X4. Volume 2 des prises électriques ne sont pas permis.
Electric installation work may only be carried out by approved specialists according to the local regulations. Liability will only be accepted by us when our products are installed by qualified engineers. The light sources incorporated in this product should only be replaced by the manufacturer, or by another similarly well-qualified person.
Rooms with bath or shower have to be protected with residual-current-operated protective device (RCD) FI (RCD) I Δ n = 30mA.
Volume 2 min. protection IP X4. Volume 2 no socket admitted.

- CH** SEV NIN 2015 1000 - 7.01
- DE** VDE 0100 - 701
- GB** BS 7671 - 601
- NL** NEN 1010

CE Dieses Produkt ist nach den aktuellen Richtlinien geprüft.
Ce produit est examiné selon les directives actuelles.
The product is controlled after current guidelines.

Eignet sich nur für Innenräume
Uniquement montage intérieur
Indoor installation only



Dieses Produkt darf nicht mit normalem Haushaltsabfall entsorgt werden.
Ce produit doit être jeté séparément des ordures ménagères.
The product must be disposed of separately from normal household waste.

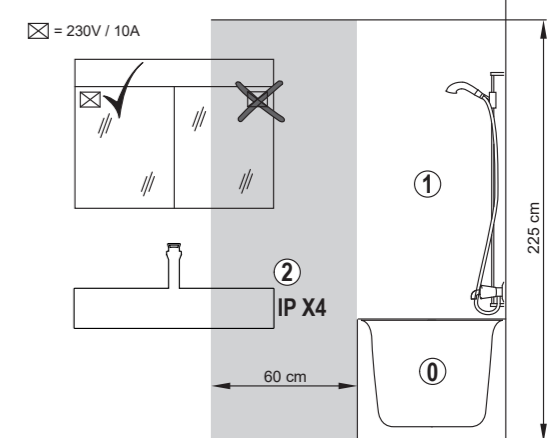

Lieferumfang / Contenu de la livraison / Scope of delivery	50, 60, 70, 80 cm	90, 100, 120, 130 cm	150, 180 cm
Spiegelschrank / Armoire-miroir / Mirror cabinet	1	1	1
Glasablage / Tablette en verre / Glass shelf	2	4	6
Aufhängeschiene / Rail de suspension / Suspension rail	2	2	2
Schraubenset / Jeu de vis / Set of screws	1	1	1
Vergrößerungsspiegel / Miroir grossissant / Magnifying mirror	1	1	1

1 Montage-Anleitung
Instructions de montage
Assembling instructions

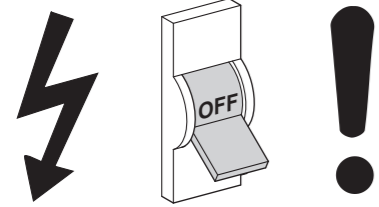

Vor dem Beginn vom Netz trennen.
Au début séparer du réseau.
Turn off electricity before beginning.

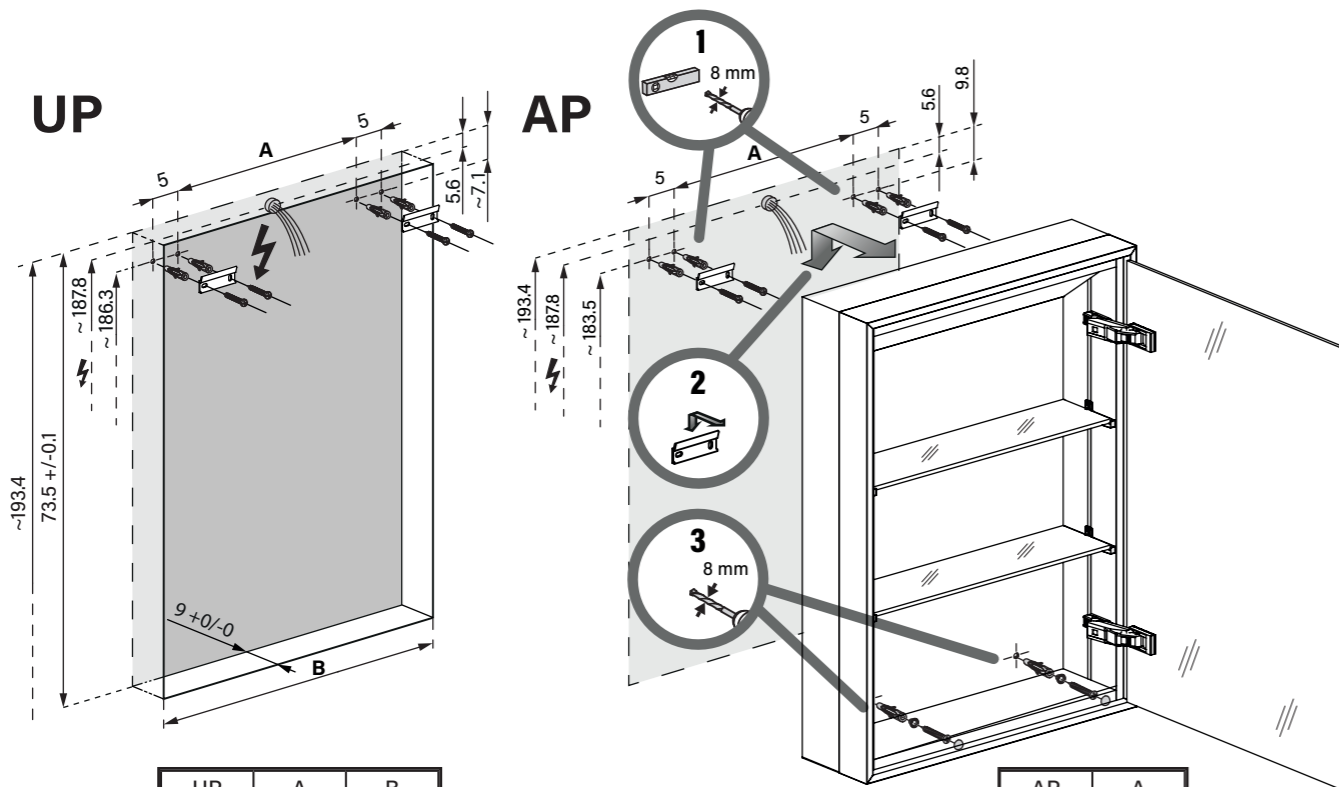
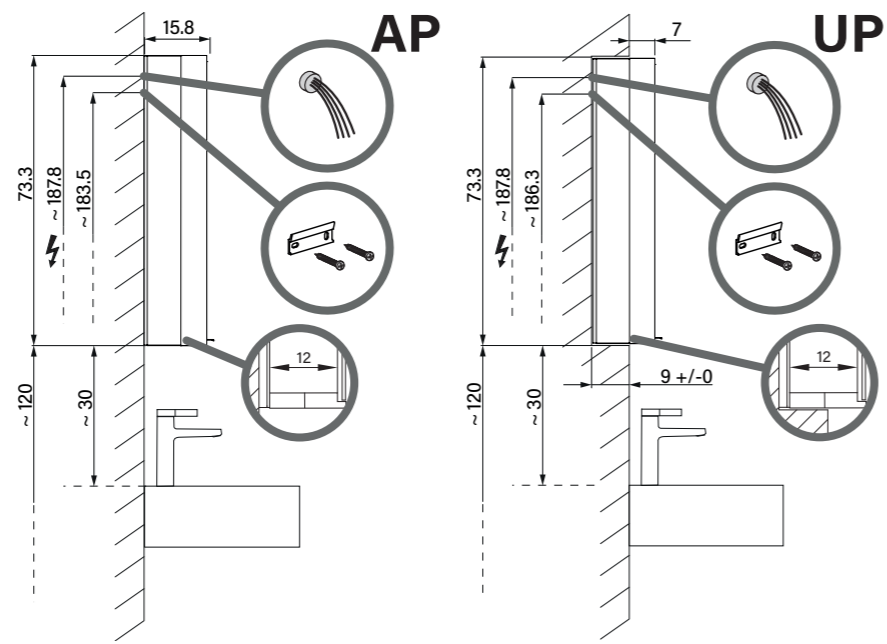

UP	A	B
50..	34.6	53
60..	44.6	63
70..	54.6	73
80..	64.6	83
90..	74.6	93
100..	84.6	103
120..	104.6	123
130..	114.6	133
150..	134.6	153
180..	164.6	183

AP	A
50..	19
60..	29
70..	39
80..	49
90..	59
100..	69
120..	89
130..	99
150..	119
180..	149

Schneider

2 Verdrahtung
Raccordement
Wiring

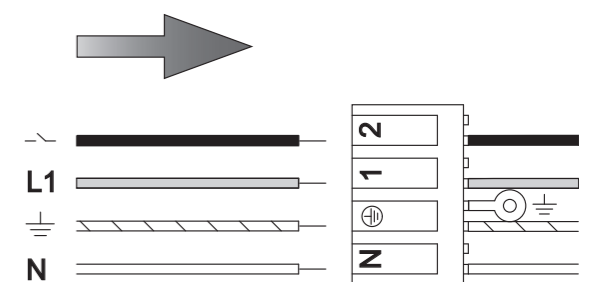
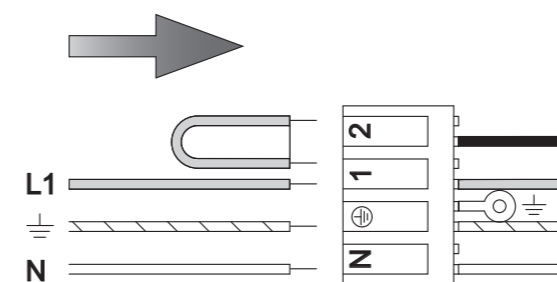
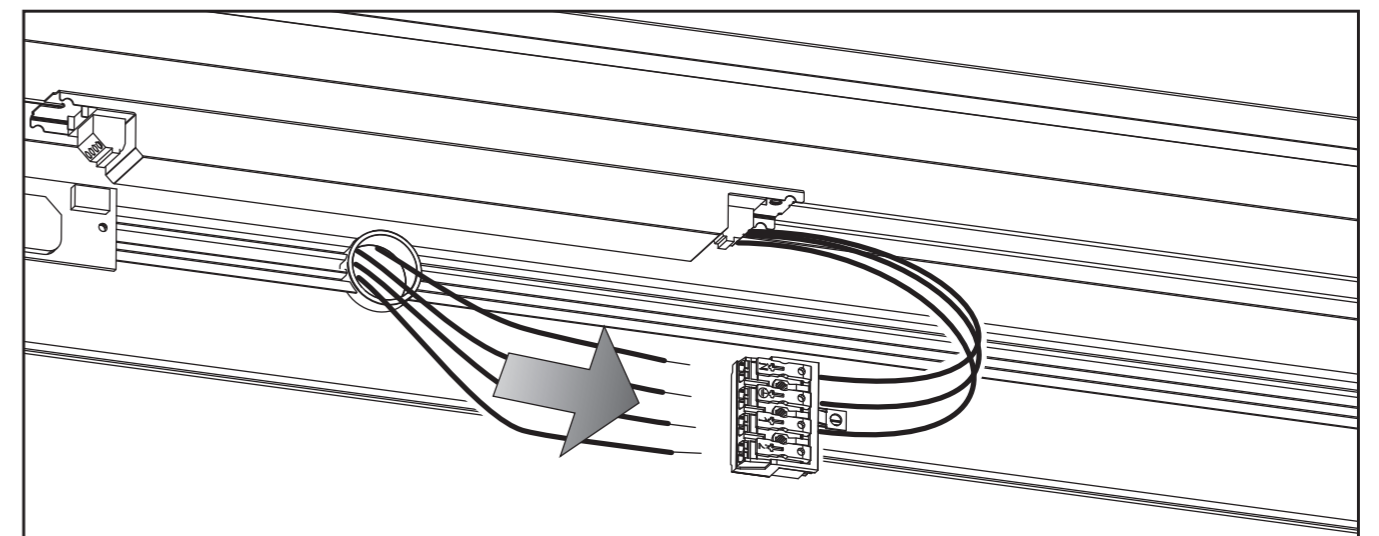
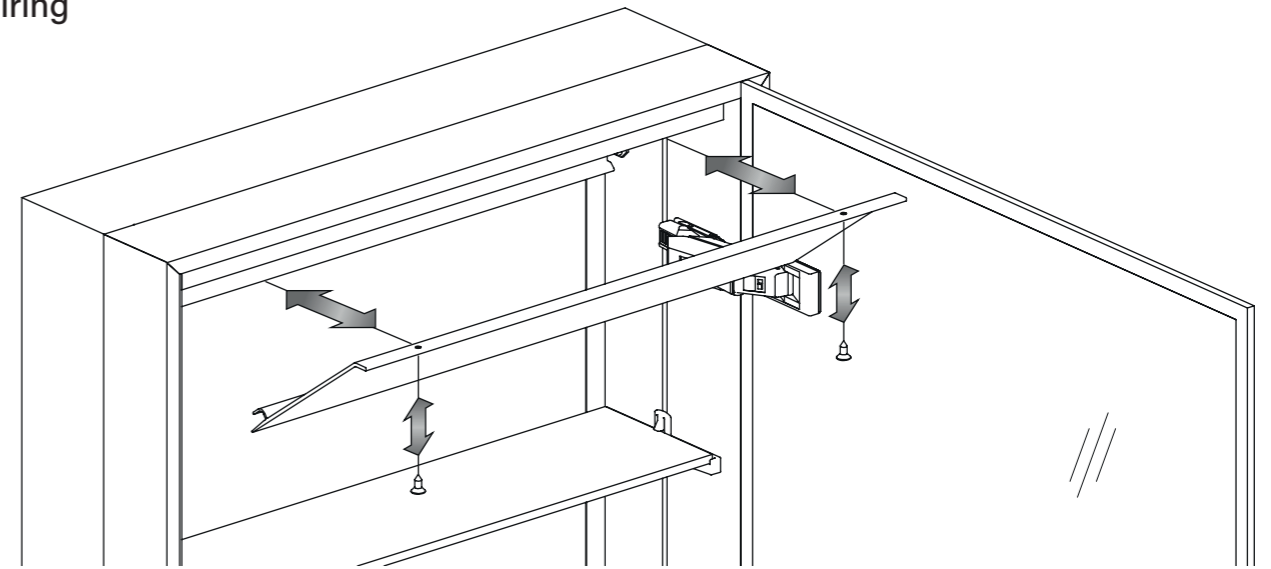

Schneider